

Panhard Rod

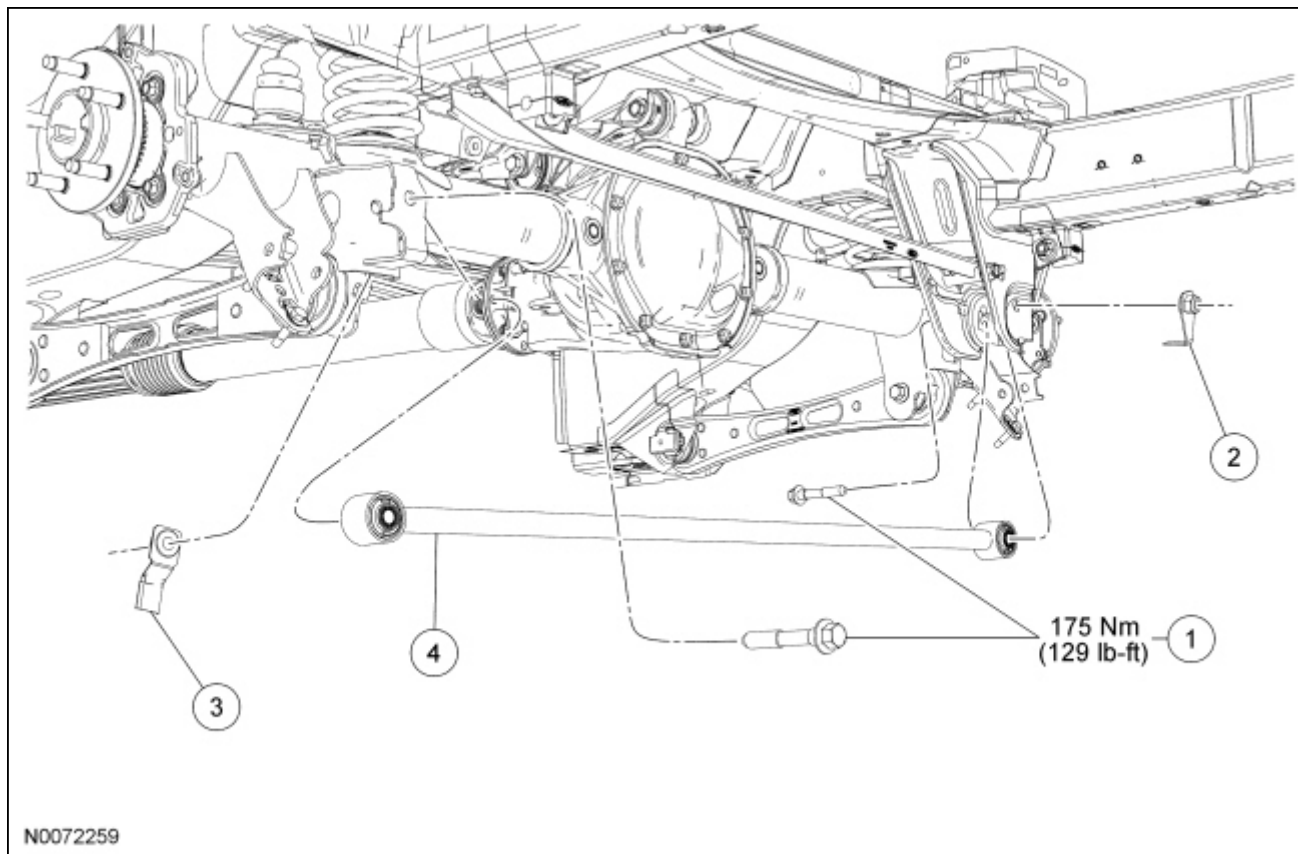

N0072259

Item	Part Number	Description
1	W704886	Panhard rod bolts (2 required)
2	W710022	Panhard rod flagnut (RH)
3	W710689	Panhard rod flagnut (LH)
4	4264	Panhard rod

Removal and Installation

NOTICE: Suspension fasteners are critical parts because they affect performance of vital components and systems and their failure may result in major service expense. New parts must be installed with the same part numbers or equivalent part, if replacement is necessary. Do not use a replacement part of lesser quality or substitute design. Torque values must be used as specified during reassembly to make sure of correct retention of these parts.

1. To aid in installation, mark the rear shock absorber relative to the protective sleeve with the vehicle in a static, level ground position (curb height).

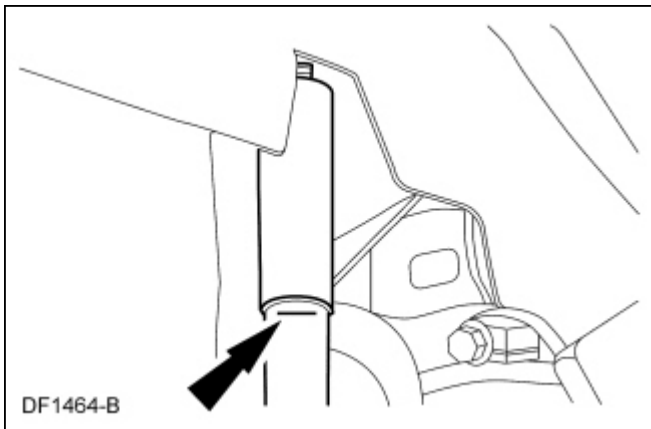

2. With the vehicle in NEUTRAL, position it on a hoist. For additional information, refer to [Section 100-02](#).
3. **NOTICE: Do not support the rear axle at the differential housing or damage to the housing may occur.**

Using 2 suitable jackstands, support the rear axle.

4. Raise the rear axle so the mark made on the rear shock absorber in Step 1 lines up with the protective sleeve.

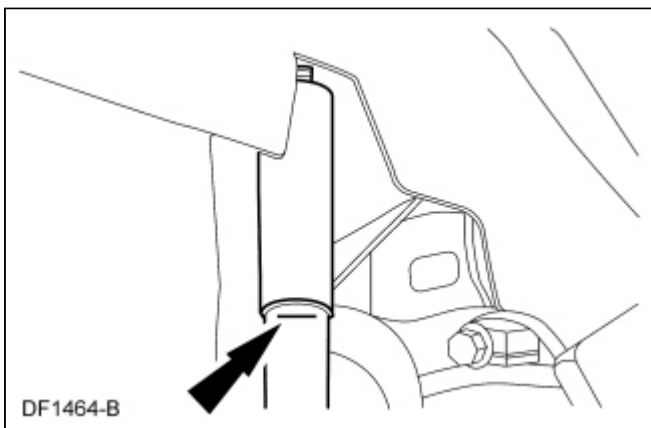

5. Using 2 screwdrivers inserted through the access hole, depress the tabs of the panhard rod bolt cover retaining clip and remove the cover.

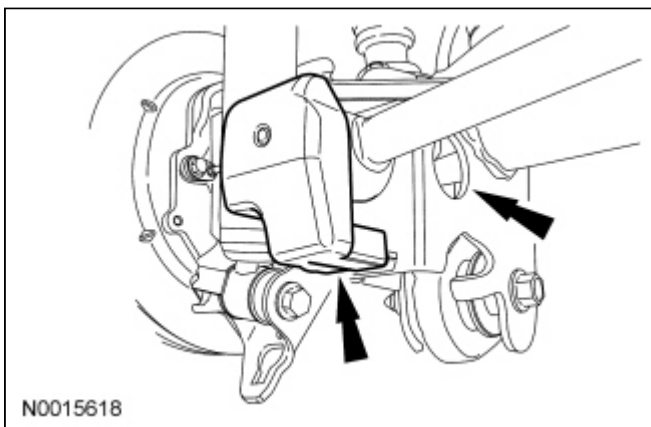

6. Remove and discard the panhard rod bolts and flagnuts.
 - To install, tighten the new bolts to 175 Nm (129 lb-ft).

7. **NOTICE:** Tighten the LH and RH panhard rod bolts with the suspension at curb height or damage may occur.

To install, reverse the removal procedure.
